

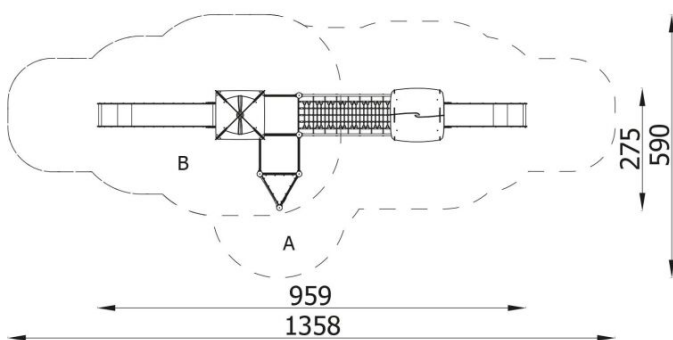

DESCRIPTION

1 tower with roof, 1 tower with gable roof, 1 triangular platform, 2 square platforms, 1 tubular bridge, 1 long slide, 1 deep slide, 2 walls with decorative cuts, 7 safety HDPE boards with decorative cuts, 2 square landings, 3 entrance, 5 climbing bars, 2 metal bars over the slide, 13 metal fittings to be installed in the ground

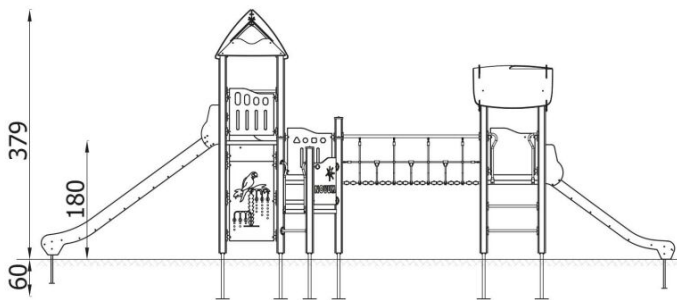

INFORMATION

Number of users	19
Age range	3 - 14
Device dimensions [m]	2.75 x 3.79 x 9.59
Compliance with the norm	EN-1176-1:2017-12
Spare parts	

SAFETY SURFACE

Zone	Max height of fall [m]	Area [m ²]	Perimeter of safety zone [m]
A	1.5	25	33
B	1.8	26.5	
C			