

# Ship with Sandpit Quadro 12512MPN

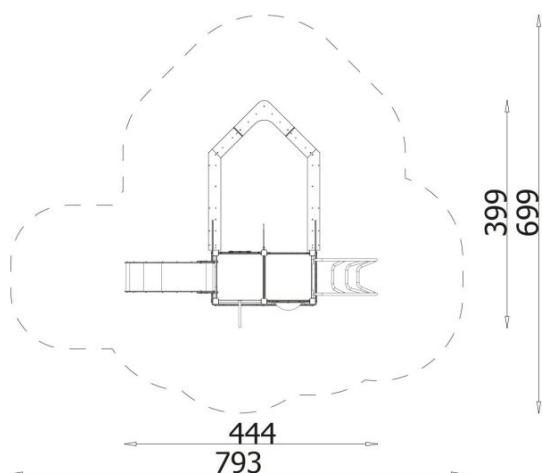
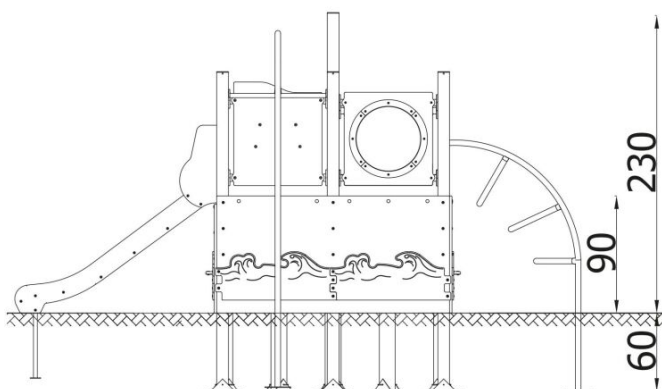
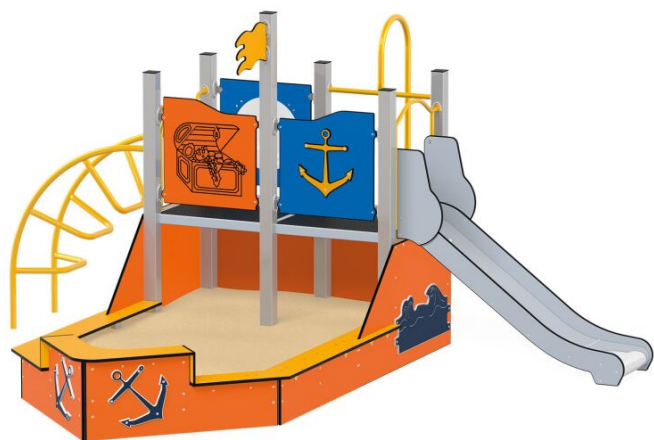

## DESCRIPTION

2 square platforms, stainless steel slide, fireman pole, arch entrance, 7 security panels, steering wheel, sandbox

## INFORMATION

Number of users	15
Age range	3 - 14
Device dimensions [m]	3.99 x 2.3 x 4.44
Compliance with the norm	EN 1176
Spare parts	

## SAFETY SURFACE

Zone	Max height of fall [m]	Area [m <sup>2</sup> ]	Perimeter of safety zone [m]
A	1	37	24
B			
C			