

DESCRIPTION

2 square platforms, triangular platform, stainless steel slide, fireman pole, vertical climbing wall, climbing trap, 16 security panels steering wheel



INFORMATION

Number of users	10
Age range	3 - 14
Device dimensions [m]	3.94 x 3.21 x 4.93
Compliance with the norm	EN-1176-1:2017-12
Spare parts	

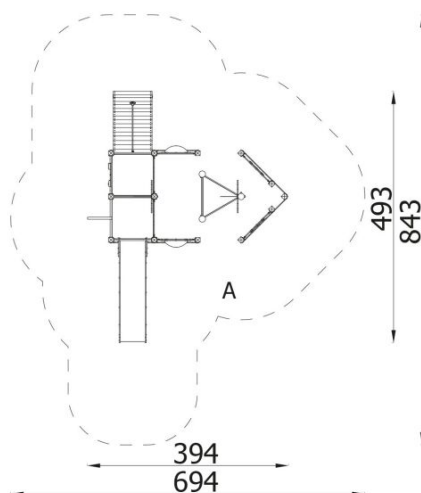
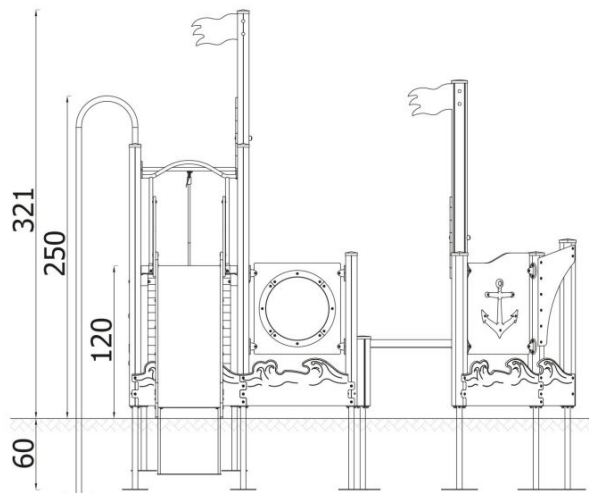

SAFETY SURFACE

Zone	Max height of fall [m]	Area [m ²]	Perimeter of safety zone [m]
A	1.2	38	25
B			
C			